

AlGaAs / Infrared Laser Diode

ADL-83Y51TL

830nm 250mW High Power Operation

Features

Small far field angle

Applications

Light source for sensor
Industry

Absolute maximum ratings

Parameter	Symbol	Condition	Rating	Unit
Light output power	P_O	CW	270	mW
Reverse voltage (LD)	V_{RL}	-	0	V
Reverse voltage(PD)	V_{RD}	-	30	V
Forward current(PD)	I_{FD}	-	10	mA
Case temperature	TC	-	-10~+60	°C
Storage temperature	TS	-	-40~+85	°C

6-2D-LD83-003_Rev.00

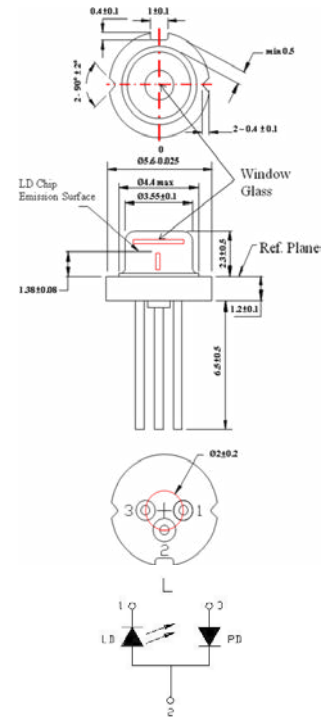

Electrical and optical characteristics ($T_c=25^\circ\text{C}$)

Parameter	Symbol	Min.	Typ.	Max.	Unit	Conditions
Peak wavelength	λ	820	830	840	nm	$P_o=250\text{mW}$
Threshold current	I_{th}	-	75	100	mA	
Operating current	I_{op1}	-	300	350	mA	$P_o=250\text{mW}$
Operating voltage	V_{op}	-	1.9	2.4	V	$P_o=250\text{mW}$
Differential efficiency	η	0.9	1.0	-	mW/mA	$P_o=200\text{-}250\text{mW}$
Monitor current	I_m	0.4	1.1	1.9	mA	$P_o=250\text{mW}$, $V_{RD}=5\text{V}$
Parallel divergence angle	$\theta_{//}$	5	7	12	deg	$P_o=250\text{mW}$
Perpendicular divergence angle	θ_{\perp}	10	14	20	deg	
Parallel FFP deviation angle	$\Delta\theta_{//}$	-3	0	3	deg	
Perpendicular FFP deviation angle	$\Delta\theta_{\perp}$	-3	0	3	deg	
Emission point accuracy	$\Delta x\Delta y\Delta z$	-50	0	50	um	

* Sufficient heat dissipation is required for CW operation.

• Precautions

- * Do not operate the device above maximum ratings even short period of time. Doing so may cause unexpected and permanent damage to the device.
- * Take precautions to avoid electrostatic discharge and/or momentary power spikes. A change in the characteristics of the laser or premature failure may result.
- * Proper heat sinking of the device assures stability and lifetime. Always ensure that maximum operating temperatures are not exceeded.
- * Observing visible or invisible laser beams with the human eye directly, or indirectly, can cause permanent damage. Use a camera to observe the laser.
- * No laser device should be used in any application or situation where life or property is at risk in event of device failure.
- * Specifications are subject to change without notice. Ensure that you have the latest specification by contacting us prior to purchase or use of the product.

For reference only. Contents above are subject to change without notice.